

OWNER'S MANUAL

Read Instructions Before Using Your New Electric Scooter



TABLE OF CONTENTS

TABLE	OF
CONTENTS.....	2
IMPORTANT INFORMATION.....	3-4
QUICK REFERENCE.....	5
GETTING TO KNOW YOURSCOOTER.....	6
PACKAGE CONTENTS.....	7
GETTING STARTED.....	7
ASSEMBLY.....	7-8
WEAR THE HELMET AND KNEE PADS	9
WHAT IS NFC.....	10
SUPER CARD PREPARARATION KEY INSTRUCTIONS	10
HOW TO OPERATE THE SCOOTER.....	11
CHARGING	12
STORAGE	13
BRAKING SYSTEM.....	14
TIRE PRESSURE.....	15
MAINTENANCE.....	16
SAFETY INSTRUCTION.....	17-18
PREVENTING DANGEROUS DRIVING.....	19
PICTRUES FOR SAFETY INSTRUCTION.....	20

PLEASE BE SAFE WHEN RIDING

ALWAYS WEAR A HELMET AND OBEY ALL LAWS!

IMPORTANT

BATTERY MAINTENANCE and CHARGING INSTRUCTIONS

1. You **MUST** charge completely prior to initial use. (Follow charging instructions in your Product Handbook)
2. Charge immediately after each use.
3. Charge before storage. You must charge every 30 days if not in use.
4. Charge the unit for 4-8 hours or until the light on the charger turns green.
5. **DO NOT** allow this unit to deep discharge the battery.
6. For safety purposes, **DO NOT** charge for over 24 hours.
7. Turn the unit **OFF** when not in use.

WARNING

This **PRODUCT IS NOT INTENDED FOR EXTREME or OFF-ROAD Use!** Please take care of your scooter!

DO NOT JUMP or ABUSE THIS PRODUCT!

DO NOT RIDE IN WET/ICY CONDITIONS!

IMPORTANT

PLEASE READ THIS BEFORE USING THIS PRODUCT

READ THIS FIRST!

WARNING

This product does not conform to Federal Motor Vehicle Standards and is not intended for operation on public streets, roads or highways. Serious injury can result from the unsafe operations of this product. Operator can minimize these risks by using certain safety equipment such as: safety helmet, goggles, gloves, elbow and kneepads and appropriate footwear.

DO NOT operate this product in traffic, on wet, frozen, oily or unpaved surfaces or under the influence of drugs and/or alcohol. Avoid uneven surfaces, potholes, surface cracks and obstacles.

DO NOT use a water hose to clean this product. See Product Handbook for more information.

This product is recommended for riders 14 YEARS OF AGE and older.

SAFETY

- Persons without excellent vision, balance, coordination, reflex, muscle and bone strength and good decision-making capabilities should not use this product.
- Minors without adult supervision should not use this product.
- Persons unwilling or unable to take responsibility for their own actions should not use this product.
- The user of this product assumes ALL risks associated with its use. To minimize these RISKS, the user must wear safety helmet, goggles, gloves, elbow and kneepads and appropriate footwear.
- This product is ELECTRIC! DO NOT ride this product in wet conditions,

QUICK REFERENCE SAFETY GUIDE

SAFETY GUIDE

- The recommended minimum age for riding this scooter is 14 years old.
- To avoid damage to the motor and footplate, do not overload the scooter.
- Never ride with more than one person.
- Inspect your scooter thoroughly before each use for loose or missing parts.
- Avoid unintentional starts by turning the scooter off while not in use.
- To avoid the risk of a short circuit in the electrical parts, do not use your Electric scooter in the rain and never spray or wash off your scooter with water.
- Do not place the battery near fire or heat.
- To avoid damage to the battery, do not use the charger if it has been damaged in any way.
- Keep hands, face, feet and hair away from all moving parts.
- Do not touch the motor or wheels while they are rotating.
- Brakes are designed to control speed as well as stop the scooter. Practice braking for proper slowing down and smooth stops.
- Maintain your SCOOTER as recommended in this Product Handbook.
- Use only quality replacement parts as recommended by the manufacturer.
- Inspect the entire scooter prior to each use. Replace any part that is cracked, chipped or damaged before use.

***NEVER ALLOW CHILDREN TO OPERATE THE SCOOTER WITHOUT ADULT SUPERVISION.**

***NEVER ATTEMPT TO OPERATE THE SCOOTER WHILE UNDER THE INFLUENCE OF ALCOHOL.**

**If a situation arises that is not covered in the manual,
proceed with caution and use good judgment.**

**Contact your dealer
if you need further assistance**

GETTING TO KNOW YOUR H10 SCOOTER

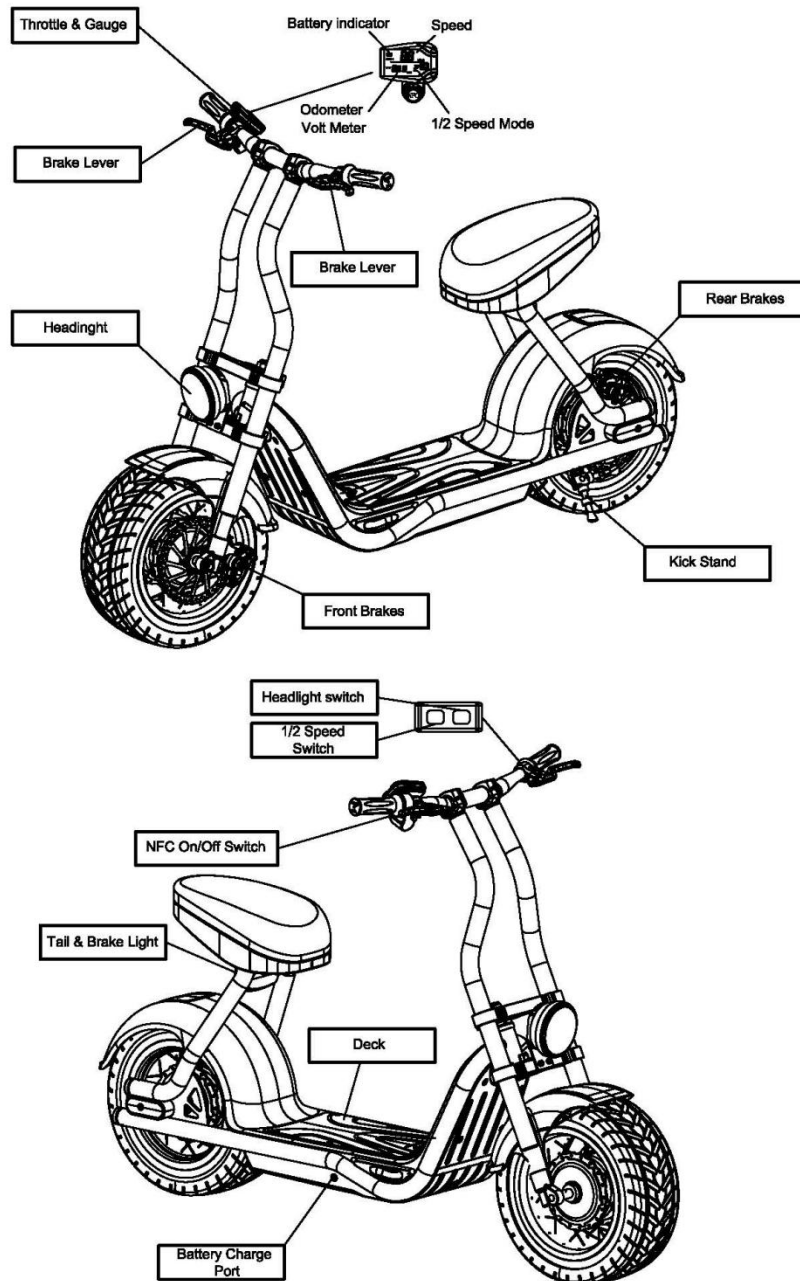

PACKAGE CONTENTS

Your Scooter comes with the following items in the box. Please locate all of the following:

1. Scooter
2. Battery Charger
3. Tool Kit
4. User Manual

ASSEMBLING THE SCOOTER

 Please read and understand these instructions and the **OPERATING PROCEDURES** section, prior to starting or riding your scooter 

Assembly

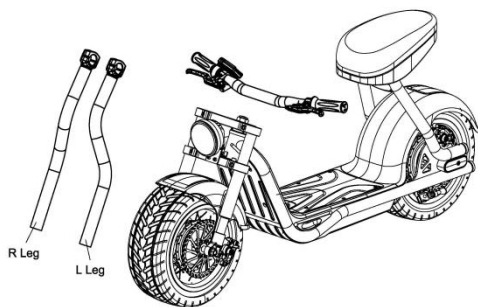

1. Take out the scooter from package carton. you can see it just like the picture A show.

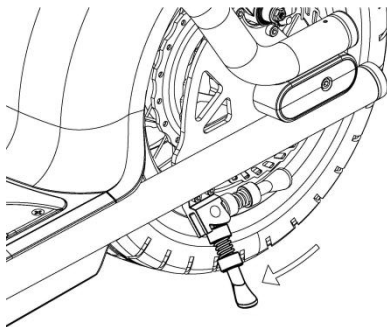

2. Kick stand position will be like this way.

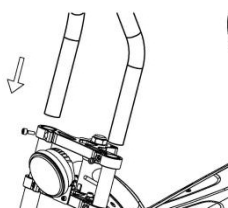

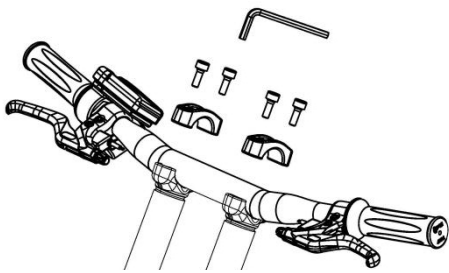

Wear helmet and knee pads before Operate The Scooter:

Please wear helmet and knee pads when practice

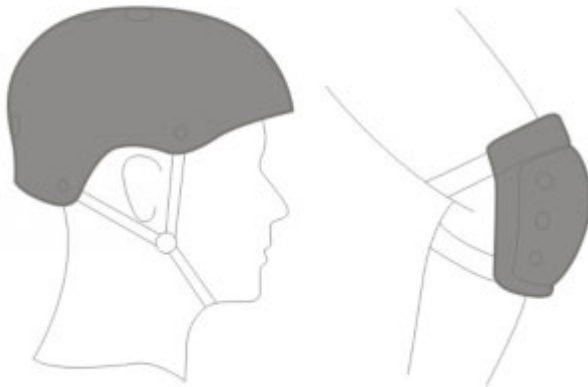

WHAT IS NFC

1. **Near Field Communication (NFC)** is a set of short-range wireless technologies, typically requiring a distance of 4cm or less to initiate a connection. NFC allows you to share small payloads of data between an NFC tag and an Android-powered device, or between two Android-powered devices. Tags can range in complexity.

Super Card Preparation Key Instructions

1. A is the key and B is the super card. When the key is lost, the manufacturer needs to send a blank card to the customer and use the super card to copy it. So be sure to keep

the super card well. Once the super card is lost, the key cannot be copied

2. Just put the super card on the induction lock, hear the beep sound, the sound lasts for 8 seconds, remove it when there is no sound
3. Paste the new chip key on the induction lock, remove it when you hear a beep, wait for 8 seconds, and the key is prepared

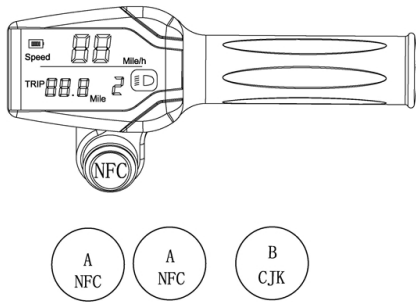

the card mark with CJK is super card

How to operate the scooter

1.Start the NFC card.You can use the NFC card to touch the NFC show on the Picture.

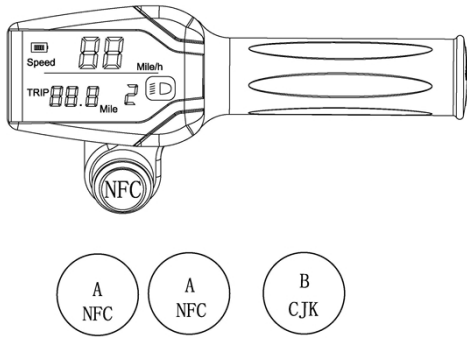

2.press the throttle,then you can go.

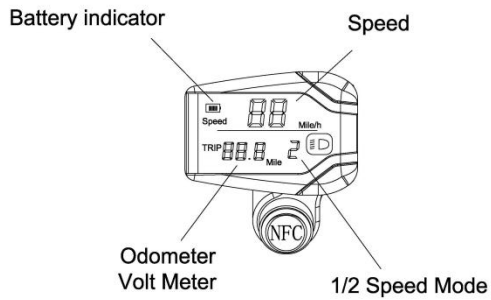

3. you can choose speed mode on the LCD.
Speed mode 1 top speed 20 km/h
Speed mode 2 top speed 40 km/h

CHARGING

Your scooter comes charged out of the carton. We still recommend charging the unit for

4-8 hours prior to it's first use. We also recommend charging your scooter after each use and prior to storage.

WARNING: Do not allow your scooter to go into deep discharge, as this will damage the batteries.

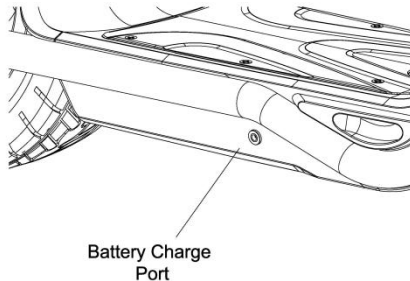

1. Make sure unit is turned off.
2. Open the charging socket cover located on the footplate.
3. Locate your Battery Charger. Find the charger socket end that has a socket and plug it into the scooter.
4. Next, plug the AC plug into a wall outlet.

When first plugged in, the charger has one red light that will illuminate at the same time, indicating that the charging process has started. Once the light on the charger turns green, you may remove the charger and close the safety cap.

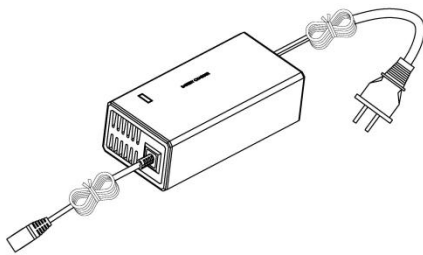

times or partial charging is okay. You will get over 75% charge in 4 hours. There is no need to fully cycle the battery every time you ride with Lithium batteries. You can ride for an hour and charge to full again if you like. When the minibike is not in regular use, recharge the battery at least once every 3 months until normal use is resumed. Turn power switch “ OFF ” before charging and conducting any maintenance procedures. Expect up to 600 charge and discharge cycles. Charging and discharging the battery in extreme temperatures above 110° F and below 32° F can cause damage to the battery.

The Li-ion battery and charger are to be used together. Do not use chargers from other model bikes—USE ONLY battery chargers.

WARNING: Rechargeable batteries are only to be charged under adult supervision. Always disconnect your electric mini bike from the charger when the battery is fully charged and before cleaning with liquid.

The charger has a small window with one LED to indicate the charge status. A Green

Light indicates the charger is on and a Red light indicates the charger is charging. When the battery is fully charged the indicator will change from a red light to a green light signifying the battery is fully charged. The charger will get warm during use, this is normal and is no cause for concern. If your charger does not get warm during use, it does not mean that it is not working properly.

For the first 5 charge cycles we recommend that you discharge the battery to 39-42 volts and then fully recharge, uninterrupted until the battery is full. Typical recharge time: up to 5 hours, depending on level of depletion. After the first 5 discharge cycles, shorter charging

RIDING

1. Make sure that all of the exposed bolts and screws are tightened.
2. Raise the kickstand to its upright position.
3. Push the on/off switch (located on the left handlebar) to the ON position.
4. Put one foot on the deck of the scooter while pushing off with the other foot, gently rotate the THROTTLE GRIP, on the right side of the handlebars. The discovery will begin to move on its own power.

**Your scooter has a variable speed hand throttle. You can control the speed of your scooter by the amount of pressure you use when rotating the hand throttle. The more you rotate, the faster you will go.

STOPPING & BRAKING

1. To brake, release the THROTTLE GRIP and depress the BRAKE LEVERS (on the left/right side of the handlebars. Depressing the brake will disengage power to the motor. When the unit feels like it is losing power or not accelerating to full speed,

the scooter is ready to be re-charged.

NOTE: If the on/off switch is left in the ON position for more than 10-15 minutes without moving, Smart Power will shut itself OFF. To reset, turn the unit OFF, wait a few seconds and then switch it back ON again.

FOLDING & STORAGE

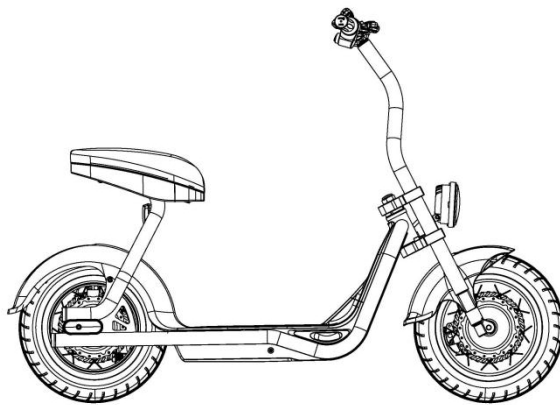

When you are done riding the scooter you can fold it down for compact storage and transportation. First remove the seat post and seat, then using one hand, push down on the folding handle while gently pushing down on the handlebars. BE CAREFUL NOT TO HIT YOUR HEAD WITH THE HANDLEBAR, SET YOURSELF AT THE RIGHT SIDE IS NECESSARY. Push down until you feel the mechanism lock into the down position.

BRAKING SYSTEM

The scooter uses a disc/caliper for the front, and a disc/caliper system for the rear. They are both activated by a hand brake lever on the left and right side of the handlebar. Squeezing the hand brake lever with your left hand activates the rear brake. Squeezing the hand brake lever with your right hand activates the front brake. Make sure to release the HAND THROTTLE GRIP when engaging the brakes. Your Discovery is equipped with switches on each brake lever that will disengage power to the motor when the brake levers are depressed.

Practice braking on a smooth, dry surface to get used to the feel of the braking system. Braking distance is affected by wet conditions and loose and uneven riding surfaces.

Adjusting the Brakes

The Brakes on the scooter should come fully adjusted from the factory. However, it may be necessary to adjust the brakes from time to time.

To adjust the rear brakes:

For brakes that are adjusted too loose:

1. Adjust the tension screw on the right hand brake lever by rotating it counter-clockwise until the wheel spins freely.

For brakes that are adjusted too tight:

2. Tighten the tension screw on the right hand brake lever by rotating it clockwise until the wheel has a slight drag.

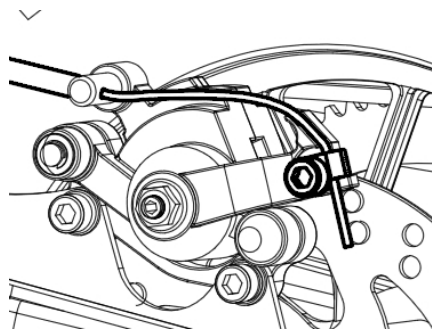

To adjust the front brakes:

For brakes that are adjusted too loose: allen wrench 6mm

3. Adjust the tension screw on the left hand brake lever by rotating it counter-clockwise until the wheel spins freely.

For brakes that are adjusted too tight: Use allen wrench 6mm

4. Tighten the tension screw on the left hand brake lever by rotating it clockwise until the wheel has a slight drag.

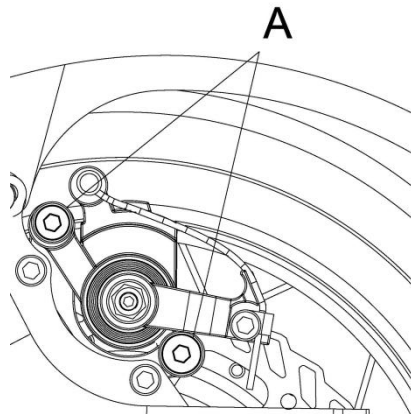

SQUEAKY BRAKES

The brakes may squeak before they are broken in. This is normal and will not affect the function or performance of the brakes. With continued use the squeak should go away.

TIRE PRESSURE

The tire must be inflated to a maximum of 40 P.S.I. when it starts from the factory. The tire is inflated to 28 PSI-30 PSI. We don't recommend it to be inflated to 40 PSI in summer. It is also recommended to use a tube additive like **Slime**, available from any motorcycle shop, to avoid inconvenient punctures.

Empty all air from the tire, prior to loosening the bolt to split the rim.

MAINTENANCE

RECOMMENDED TOOLS

To adjust and service the scooter you will need the following tools:

- Allen Wrenches: 3/5/6 mm
- Wrenches: 10/12/13/14/17/19 mm
- Screwdrivers
- toolbag

MAINTENANCE SCHEDULE

Proper care of your scooter will insure optimal performance and longer life span. The following are a few maintenance suggestions that will keep your scooter running in top condition:

Daily Maintenance

Perform each time you ride your scooter

- Clean the exterior of the unit with a soft, damp rag. (DO NOT WASH WITH A HOSE)
- Check that all nuts and bolts are securely tightened.
- Check battery charger for any frayed/cut wires.

Clean and store Electric Scooter

If you find any stains on electric scooter housing, use a soft, damp cloth to wipe the vehicle; You can use toothpaste and a toothbrush to clean the scooter

from stains, and then wipe it clean with a damp cloth. If you find scratched on parts, made of plastic, use sandpaper or other grinding materials for their polishing.

Warning: Do not use alcohol, petrol, kerosene or other corrosive solutions, volatile chemical solvents to clean the vehicle. Otherwise, it will cause serious damage to the scooter body and can disrupt a structure of internal elements. Do not wash electric scooter under a strong pressure of the water, make sure the scooter in the off status. In addition, after charging of the vehicle, it is necessary to insert a plug back to a charging connector, otherwise you may get an electric shock, or may have serious water damage cause from water falling into this hole may have serious water damage

If you do not use the scooter, store it in a dry, cool place and do not leave the unit for a long time on the street. Leaving the device under the sun/in extremely high temperature/over-low temperature can cause rapid aging of an outer body and wheels of Electric Scooter or reduce battery life.

Maintenance of Electric Scooter battery

- 1) Do not use batteries from other brands in order to avoid a dangerous situation;
- 2) Do not open or disassemble the battery to prevent electric shock. Avoid contact with metal objects to prevent an occurrence of a short circuit. Otherwise, the battery may have malfunction or can injure the user;
- 3) It is recommended to use an AC adapter.

SAFTY INSTRUCTION

the device, to prevent an occurrence of an accident or fire of the vehicle;

- 1) Improper disposal of used batteries and accumulators is the cause of severe environmental pollution. Please, dispose of batteries in accordance with local laws. Please do not dispose of batteries together with food waste. Protecting the environment together!

2)After each use of the device, charge the battery to prolong its service life.

Do not store the scooter battery in rooms with temperatures, that exceed

50°C or 20°C (for example, do not leave the battery of Electric Scooter and other

batteries in cars in summer time on the hot sun), do not leave the battery near

fire. As a result of these actions may deteriorate the battery, overheating and can

even cause inflammation.

If within 30 days the scooter is not used, charge the battery and keep the device in

a cool, dry place. Every 60 days you need to charge the battery, otherwise there is

the likelihood of its failure, which is not subject to warranty services.

Avoid a full discharge of the device, it will extend battery life.

When using the

device at normal room temperature, the battery will be able to ride much greater

distance and its performance will be better; but if you use the scooter at

temperatures below 0°C, vehicle performance and permeability decrease.

At 20°C a traveled distance is less, than the scooter in the normal conditions of half

or even less. If a temperature rises, a traveled distance by the vehicle will also

increase. You can check remaining distance in the Application.

Note: A fully charge scooter runs about 120-180 days of standby time. The battery

has a smart chip, that stores information about its charging-discharging. If you are

has a smart chip, that stores information about its charging-discharging. If you are

not charging the battery for a long time, it can cause serious damage, for which it

is impossible to charge the device again. This kind of damage is not included in

free warranty service. (Caution: Do not disassemble the device by unauthorized

people, as there is a risk of electric shock or serious injury as result of a short

circuit.)

Preventing dangerous driving

It is forbidden to leave a scooter wheel at high roadway for motor vehicles or ride in at a high speed

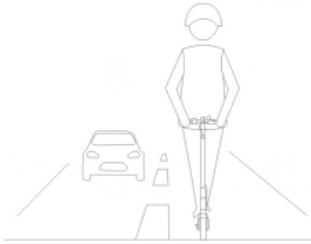

It is forbidden to drive through puddles, to which exceeds depth of 2cm



It is forbidden to sharply turn a residential area with a large flow of passers-by

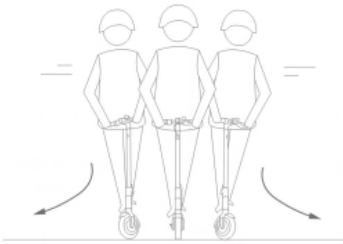

Never rider a scooter more than or one person,hold a child in your arms.



Safety Instructions

It is not recommended driving on the rain



Entering into any room, elevator, etc.

Be careful not be injured by a door frame.

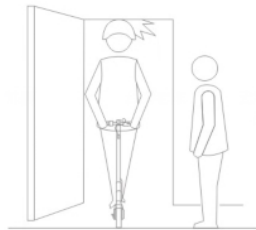

It is recommend to slightly bend knees to better adjust to a rough road. If you are travelling on a rough road, stick to low speed (5-10km/h)



Please not add speed when descending a hill

